

Version:
March 1, 2017

DIRECT

Electronics Tech.

(AHL) Aluminum Encased Heat Sinkable Resistor

Web: www.direct-token.com

Email: rfq@direct-token.com

Direct Electronics Industry Co., Ltd.

China: 12F, Zhong Xing Industry Bld., Chuang Ye Road,
Nan Shan District, Shen Zhen City,
Guang Dong, China 518054
Tel: +86 755 26055363; Fax: +86 755 26055365

Taiwan: No.137, Sec. 1, Zhongxing Rd., Wugu District,
New Taipei City, Taiwan, R.O.C. 24872
Tel: +886 2981 0109 Fax: +886 2988 7487

▶ Product Introduction

||| Power Wire wound Aluminum Encased Heat Sinkable Resistors

Features :

- High stability, strong construction.
- Standard winding & non-inductive winding types.
- High power rating, small size and ultra precision.
- Aluminum housing allows chassis mounting and provides heatsink capability.

General Specification :

- Resistance Tolerance: $\pm 10\%$, $\pm 5\%$.
- Operating Temperature Range: -55°C to $+275^{\circ}\text{C}$.
- Wattage Range: 4 styles to choose ranging from 25 to 150 watts.
- Dielectric Strength: AHL-25 1000V, AHL-50 1500V, AHL-150 2500V.

(AHL) Reach unreachable points and simplify your PCB design. Direct Electronics extended lead wire aluminum housed wire wound Power resistor (AHL) provides design engineers a flexible connection in distance between connections.

(AHL) is a high-performance axial-terminal type resistor with flexible connections. These molded-construction aluminum-chassis resistors are available in higher power ratings than standard axial-terminal resistors and are better suited to withstanding vibration, shock and harsh environmental conditions.

(AHL) resistors are aluminum encased to maintain high stability during operation and to permit secure mounting to chassis surfaces. The metal housing also provides heat sinkable capabilities, allowing the units to exceed the power ratings.

The (AHL) Series is RoHS compliant and lead free. For non-standard technical requirements and custom special applications, please contact us for details with your specific needs. Or link to Direct official website "[High Power Resistors](#)" to get more information.

Non-Inductive:

Ayrton Perry type non-inductive winding is available. When required add "N" to the part number.



► **Materials**

Materials Extended Lead Wire (AHL)

| | | | | | |
|---|--------------|--|-----------------|-------------------|---------------------|
| ① | Encapsulant | Silicone | | | |
| | End caps | Stainless steel | | | |
| | Core | Ceramic steatite or aluminum | | | |
| | Housing | Aluminum with hard anodic coating | | | |
| | Element | Copper-nickel alloy, nickel-chrome alloy or manganese copper | | | |
| ② | Wire (14AWG) | AHL-25, AHL-25N | AHL-50, AHL-50N | AHL-150, AHL-150N | AHL-150A, AHL-150AN |
| | | Length=160mm | Length=340mm | Length=500mm | Length=300mm |
| ③ | Terminals | LVA2-250, Cu (Nickel-plate), W7.5 × L10mm | | | |

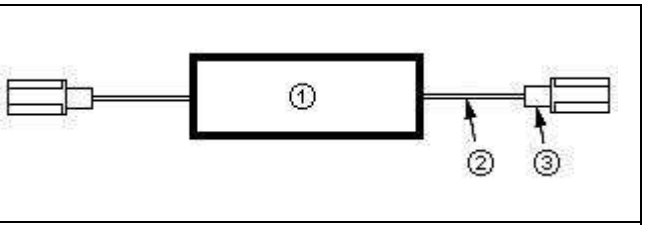

● Note: All values might be changed or modified, please consult factory for details.

► **Dimensions**

Dimensions Extended Lead Wire (AHL-25, AHL-50)

| Type | Dimensions (Unit: mm) | | | | | | | |
|-----------------|-----------------------|-----|------|---|------|----|----|----|
| | E | F | G | H | M | N | P | Q |
| AHL-25, AHL-25N | 13 | 7 | 14.3 | 2 | 18.3 | 27 | 20 | 27 |
| AHL-50, AHL-50N | 15.5 | 7.3 | 16 | 2 | 40 | 50 | 22 | 29 |

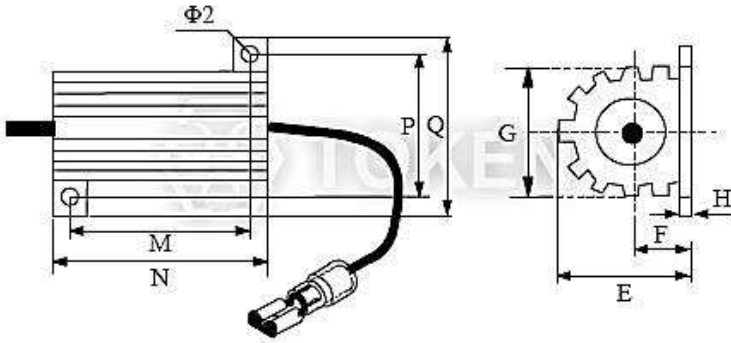

Extended Lead Wire (AHL-25, AHL-50) Dimensions

● Note: All values might be changed or modified, please consult factory for details.

Dimensions Extended Lead Wire (AHL-150, AHL-150A)

| Type | Dimensions (Unit: mm) | | | | | | |
|---------------------|-----------------------|------|----|-----|----|----|----|
| | E | F | G | H | N | P | Q |
| AHL-150, AHL-150N | 45 | 9.6 | 46 | 5 | 92 | 57 | 72 |
| AHL-150A, AHL-150AN | 26 | 11.5 | 27 | 3.5 | 97 | 37 | 48 |

Extended Lead Wire (AHL-150, AHL-150A) Dimensions

● Note: All values might be changed or modified, please consult factory for details.

Dimensions - LVA250 Terminals (AHL)

| Suitable for 14~16AWG | | I _{max} =15A | | Unit: mm | | Tol.: ±0.2mm | |
|-----------------------|------------|-----------------------|----------|----------|-----|--------------|------|
| ITEM | NEMA-TAB | Thickness | B (Ref.) | dΦ | DΦ | L | H |
| LVA 2-250 | 0.8 × 6.35 | 0.4 | 7.4 | 2.3 | 4.3 | 21.0 | 10.0 |

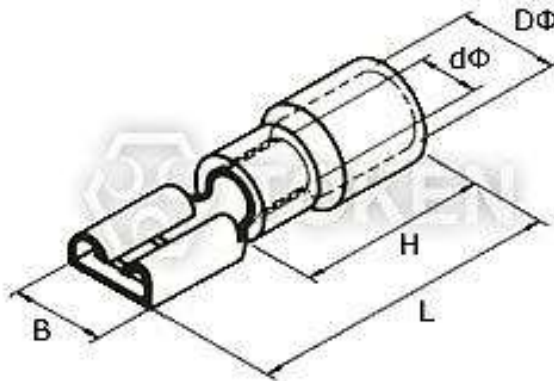

LVA250 Terminals Dimensions

● Note: All values might be changed or modified, please consult factory for details.

► **Electrical Specification**

Electrical Specification Extended Lead Wire (AHL)

| Type | Wattage Rating (W) | Resistance Range (Ω) | | Max. Working (V) | | Proper heat sink (Aluminum chassis) |
|-----------|--------------------|-------------------------------|---------------|------------------|---------------|--|
| | | Inductive | Non-inductive | Inductive | Non-inductive | |
| AHL-25 | 25 | 0.012~15K | - | 500 | - | 1077 cm ² × 1.0 mm thick or equiv |
| AHL-25N | 25 | - | 0.02~5.5K | - | 300 | 1077 cm ² × 1.0 mm thick or equiv |
| AHL-50 | 50 | 0.01~40K | - | 1300 | - | 1877 cm ² × 1.5 mm thick or equiv |
| AHL-50N | 50 | - | 0.02~12K | - | 600 | 1877 cm ² × 1.5 mm thick or equiv |
| AHL-150 | 150 | 0.4~50K | - | 1900 | - | 1896 cm ² × 3.2 mm thick or equiv |
| AHL-150N | 150 | - | 0.12~25K | - | 1340 | 1896 cm ² × 3.2 mm thick or equiv |
| AHL-150A | 150 | 0.4~50K | - | 1900 | - | 1896 cm ² × 3.2 mm thick or equiv |
| AHL-150AN | 150 | - | 0.12~25K | - | 1340 | 1896 cm ² × 3.2 mm thick or equiv |

● Note: All values might be changed or modified, please consult factory for details.

► **Heat-Sink & Derating Curve**

Surface Temperature Versus Power Load Extended Lead Wire (AHL)

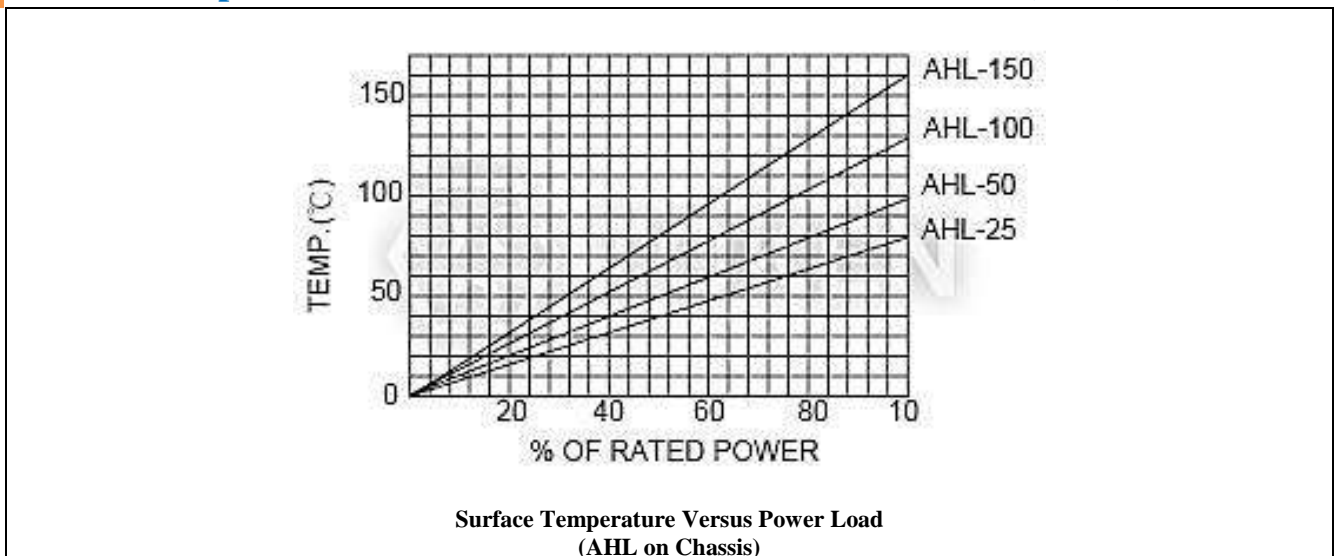

Ambient Temperature Derating (AHL)

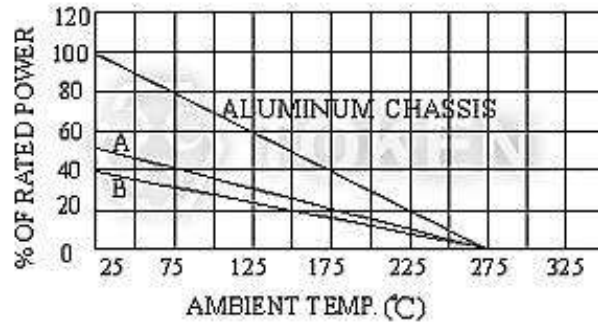

(AHL) Ambient Temperature Derating

Derating is required for ambient temperatures above 25°C, see the graph.
 Curve Aluminum Chassis applies to all types when mounted to specified heat sink.
 Curves A, B apply to operation of unmounted resistors.

- Curves A: AHL 25 watt units, unmounted.
- Curves B: AHL 50, 100 and 250 watt units, unmounted.

Reduced Heat Sink Derating (AHL)

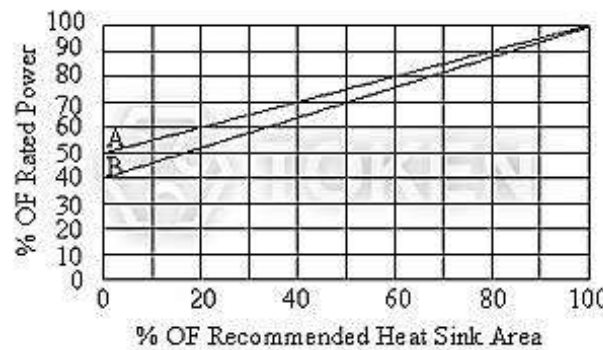

(AHL) Reduced Heat Sink Derating

Derating is also required when recommended heat sink area is reduced.

- Curves A: AHL-25 size resistor.
- Curves B: AHL-50, AHL-100 and AHL-250 size resistor.



▶ Test Conditions

Test Conditions (AHL)

| Parameters | Test Conditions | Specifications |
|------------------------------|---|--|
| Vibration | 10c/s~50c/s~10c/s (1Min) - 2Hours each of paralleled and right angle | ΔR_{\pm} (1%+0.05 Ω) Max. |
| Load Life | Load Rating (chassis mounted) (1.5Hour on 0.5Hour OFF) Repeat 1000Hours | ΔR_{\pm} (5%+0.1 Ω) Max. |
| Heat Resistance | 260 \pm 5 $^{\circ}$ C, 10 \pm 1Sec. | ΔR_{\pm} (1%+0.05 Ω) Max. |
| Terminal Strength | Pull Test (30 sec Min) 4.5kg | ΔR_{\pm} (0.2%+0.05 Ω) Max. |
| Dielectric Strength | AHL-25 1000V AHL-50 1500V AHL-100, AHL-150 2000V | ΔR_{\pm} (0.5%+0.05 Ω) Max. |
| Moisture Load Life | Temp 40 $^{\circ}$ C moisture 95% 1/10 \times wattage rating (1.5Hr on-0.5Hr OFF) - Repeat 200Hr | ΔR_{\pm} (1%+0.1 Ω) Max. |
| Moisture Resistance | Temp 40 $^{\circ}$ C moisture 95% DC 100V 500Hr | ΔR_{\pm} (1%+0.1 Ω) Max. |
| Insulation Resistance | Under the same test condition of Dielectric Strength, Load DC500V and measure the Insulation R. | 10M Ω Min. |
| Short Time Over Load | 5 \times wattage rating-5sec. | ΔR_{\pm} (2%+0.1 Ω) Max. |

▶ Order Codes

Order Codes Extended Lead Wire (AHL)

| AHL-50 | 50W | L340 | 14AWG | 510R | K | | |
|-------------------------|-----------------|--------------------|-----------|-------------------------------|----------------|--------------------------|-----------|
| Part Number | Rated Power (W) | Wire Length (min.) | Wire Type | Resistance Value (Ω) | | Resistance Tolerance (%) | |
| AHL-25 / AHL-25N | 25W | L160 | 14AWG | R51 | 0.51 Ω | J | \pm 5% |
| AHL-50 / AHL-50N | 50W | L340 | | 5R1 | 5.1 Ω | K | \pm 10% |
| | 150W | L500 | | 51R | 51 Ω | | |
| AHL-150 / AHL-150N | 150W | L300 | | 510R | 510 Ω | | |
| AHL-150A / AHL-150AN | | | | 5K1 | 5.1K Ω | | |
| | | | | 47K | 47K Ω | | |
| | | | | 47K3 | 47.3K Ω | | |



► General Information

Benefits & Features

Providing design engineers with an economical resistor with high quality performance, Direct Electronics offers industry grade power wire wound devices.

Direct provide terminal blocks, thermal switches, fusing, fans, junction boxes, screened or solid bottom plates, conduit knockouts, and customer specified requirements. For large applications a welded frame construction is utilized to provide a robust design for power resistor mounting in both indoor and outdoor environments.

Products range from large capacity metal clad, nonflammable fixed and adjustable, wave ribbon wire-wound, slide, starter, box type, to nonflammable flat type. Direct extends a complete line for both military and commercial applications.

Utilization Notes

1. Smoke emitted from non-flammable resistors on initial use in powered circuits is a normal phenomenon and the component can be safely utilized.
2. All resistors manufactured by Direct Electronics Industry Corporation comply with the U.S. UL-94 non- flammability test, Class V-0, a continuous combustion period of zero seconds.
3. Never use organic solvents to clean non-flammable resistors.
4. Non-flammable resistors cannot be utilized in oil.
5. Non-flammable resistors cannot be used in high frequency machinery because of the inductance produced by the windings. A suitable type of resistor must be selected. Contact us for details.
6. In applications where resistors are subject to intermittent current surges and spikes, be sure in advance that the components selected are capable of withstanding brief durations of increased load.
7. Do not exceed the recommended usable load. Resistors must use within the rated voltage range to prevent the shortening of service life and/or failure of the wound resistance elements.
8. Minimum load. Resistors must be utilized at 1/10 or more of the rated voltage to prevent poor conductance due to oxidation build-up.
9. Although the hardness exceeds that of a 3H pencil lead, do not nick the resistor coating with screw drivers or other pointed objects.
10. Avoid touching non-flammable resistors in operation; the surface temperature ranges from approximately 350°C ~ 400°C when utilized at the full rated value. Maintaining a surface temperature of 200°C or less will extend resistor service life.
11. Keep temperature from rising by choosing a resistor with a higher rated capacity; do not use a component having the exact load value required. For considerations of safety in extended period applications, the resistor rating should be more than four times higher than the actual wattage involved, but never use a resistor at less than 25% of its rated power.
12. Application and Placement: Wire-wound resistors use different gauges of wire as resistance elements. Sometimes the gauge is extremely thin (finer than a strand of human hair) and very susceptible to breakage in environments containing salts, ash, dust and corrosives. Avoid utilization in such environments. Do not install in dusty areas because the accumulation will cause shorts and poor conductance.

